



16CH BATTERY CELL SIMULATOR MODEL 87001

Chroma 87001 Battery Cell Simulator is a high-precision, programmable, and bidirectional DC power source with both voltage source and current source functions. In addition, the model can be used as a multi-channel DC power supply or an electronic load as well. A single simulator has 16 channels and each of them can set voltage and current respectively via Chroma software.

The Chroma 87001 Battery Cell Simulator can be used in place of lithium-ion batteries to provide a reliable and safe testing environment. The equipped battery management system (BMS) and its subsystems can test the battery cells used in electric vehicles and energy storage batteries, etc.

The simulator has voltage isolated channels that can simulate a 480-cell battery pack (2000V/4.2V) connected in series. It is used to imitate the power characteristics when charging and discharging the battery cell energy. This high-precision battery cell simulator with flexible voltage source and current load regulation has voltage and current measurement capabilities. Each channel provides 0~5V voltage adjustment capability and 0~5A bidirectional current function, with serial and parallel capabilities between

channels. The current can be increased by paralleled channels; moreover, the battery cell short circuit simulation tests can be performed via the battery management system (BMS). The BMS testing can be performed directly even when the cable length is 5m long

The Chroma 87001 Battery Cell Simulator can be used alone with user development software or integrated into a fully functional BMS test system for automated testing to complete the product verification rapidly. The simulator can test the BMS products under master/slave or independent architecture. Optional high-precision temperature simulation is available through Chroma's customized BMS test system as each battery has temperature sensor simulating function to provide the cell temperature status to BMS for testing.

The simulator has a variety of protection features such as over current protection (OCP), over voltage protection (OVP), under voltage protection (UVP), fan fail protection, and output circuit compensation voltage to make sure that the tests are conducted under a safe environment.



MODEL 87001

KEY FEATURES

- Operating mode : CC/CP
 - Channel power 25W
 - Channel voltage 5V
 - Channel current 5A (parallelable)
- Bidirectional power supply design
- Serial and parallel connection function
- 480-cell battery pack voltage simulation ability (connected in series)
- High precision current and voltage measurement
- 2 current ranges for selection per channel
- Current sharing design for parallel operation mode
- Fast voltage setting for rise/fall speed : time (1ms)
- Switch fast charge and discharge current in current source mode without any interruption
- Low output noise
- Independent channel over-voltage, current limit, and over-temperature protection
- Standard Ethernet control interface
- CE certification granted

APPLICATIONS

- BMS (Battery Management System) testing and verification
- Power tools production tests

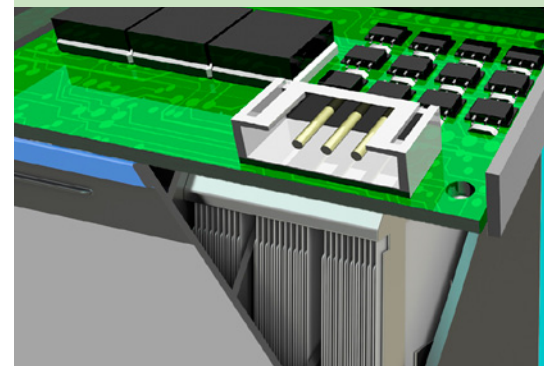

Chroma

APPLICATION ARCHITECTURE DIAGRAM (Master/Slave Architected Battery Management System)

The Chroma 87001 Battery Cell Simulator can be applied to high-voltage battery cell isolation units to simulate a variety of battery cell strings scenarios. With bidirectional voltage and current source function, it can simultaneously simulate the battery cells connected in series and the loading of external power devices to UUT. The architecture diagram shown below is an example of an integrated battery cell simulator test system that provides a battery management unit (BMU) with subsystem Cell Supervising Circuit (CSC).

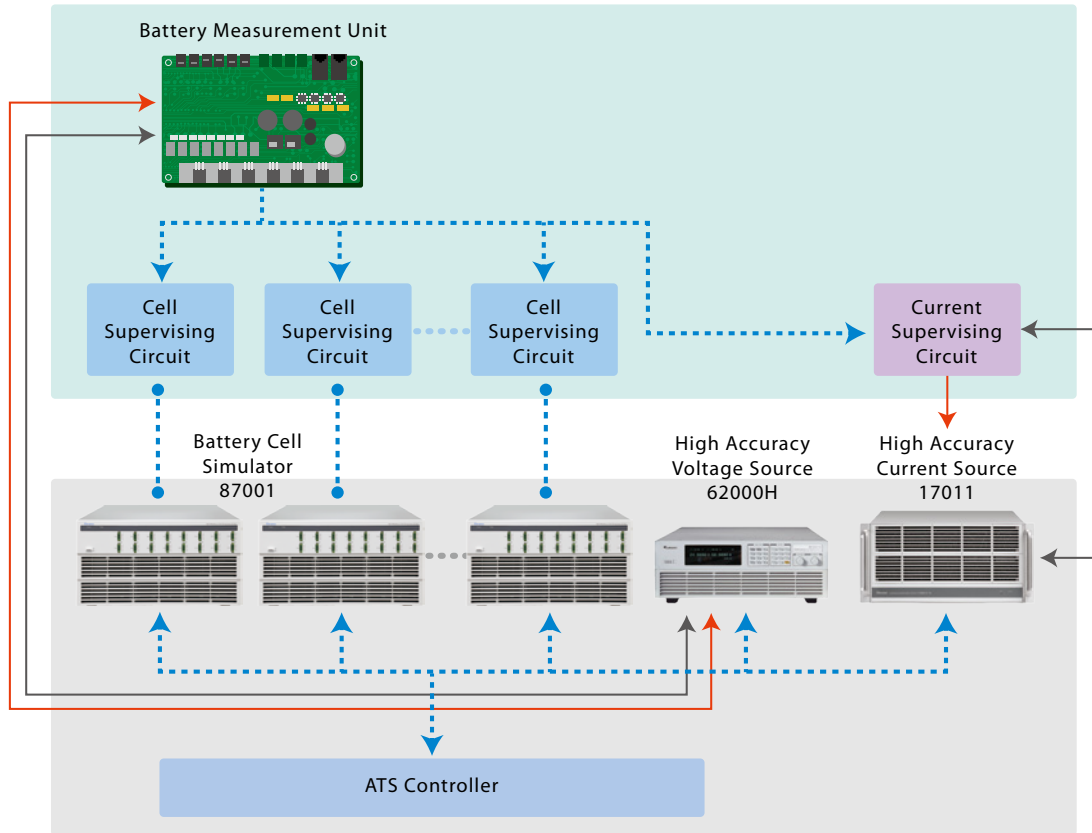

BATTERY CELL STATUS IN PARALLEL AND SERIAL OPERATION MODE

When multiple battery cells are required, the battery cell simulators can be connected in series for use. The simulator supports both serial and separate channel parallel connection modes that can simulate the battery cell status up to 480 cells. The parallel function with automatic current sharing design makes the operation quick and easy allowing for greater simplicity to the user's operating procedure. The 87001 is equipped with an Ethernet standard interface that can be used for remote control and other automated test applications.



PRECISION VOLTAGE/CURRENT MEASUREMENT

The Chroma 87001 Battery Cell Simulator has voltage source and bidirectional current source modes with a built-in 16-bit high-precision A/D converter. The voltage measurement accuracy is up to $\pm 1\text{mV}$ (0.02%FS) with resolution up to 0.1mV.

For the market trend of active and passive balance design, the current measurement is divided into 0~5.2A/0~520mA two ranges with 0.02%FS accuracy. For 0~5A (power increased in parallel connection) range, the accuracy is $\pm 1\text{mA}$, which meets most of the industry's requirements for testing the actively balancing designed circuits with a current measurement resolution up to 100uA.

For 0~500mA range, the accuracy is $\pm 100\text{uA}$ (0.02%FS.), which can meet most of the industry's passive balance designs, and the measurement resolution is up to 10uA. In addition to the passive balance for current measurement, it can also be used for cell supervising circuit to measure the current consumption of each battery cell ($> 10\text{mA}$ for general consumption).

PROGRAMMING SEQUENCE AND APPLICATION

The battery cell simulator has 16 channels that can set the voltage and current limit respectively; program the rise and fall of output voltage, and synchronize the start-up between channels via software. When the low output noise features presents the DC characteristics of a battery cell without any ripples during dynamic load changes, it can quickly provide a steady DC output. Meanwhile, it reduces the surge voltage caused by the load change that could damage the UUT. For non-static products or test applications, it can supply a stable DC voltage source in time.

The Chroma 87001 Battery Cell Simulator provides a high-speed, programmable, dynamic, and bidirectional load mode with less than 100us load change capability, simulating a variety of different true load current waveforms.

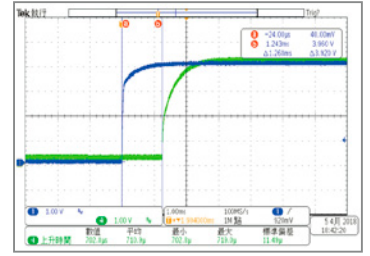

Synchronous startup time difference between channels < 2ms

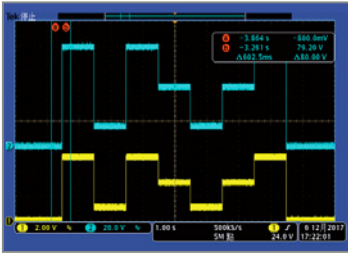

Voltage change of all channels

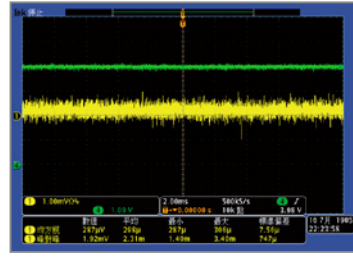

Low output noise < 0.35 mV rms

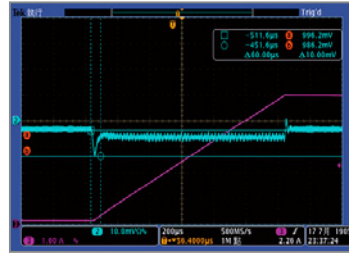

Stable DC output generated from load change

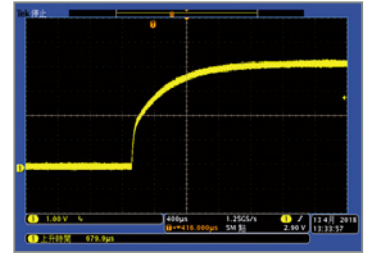

High speed voltage response < 1ms

SYSTEM INTEGRATION AND SUPPORT

The Chroma 87001 Battery Cell Simulator allows users to develop application software using the provided SCPI commands, Labview drivers, and LabWindow drivers, or to integrate into the BMS test system with assistance from Chroma.



Integrated BMS Test System (16S)



Distributed BMS Test System (96S)

REMOTE CONTROL FUNCTION

A Chroma exclusive softpanel is provided to control the battery cell simulator allowing the user to :

- Individually adjust the voltage of each string battery
- Access the battery cell curve loading function to view voltage status changes according to the voltage compared with SOC.
- Set the voltage change procedure: OVP/UVP/OVP release /UVP release test



87001 Softpanel

PANEL DESCRIPTION

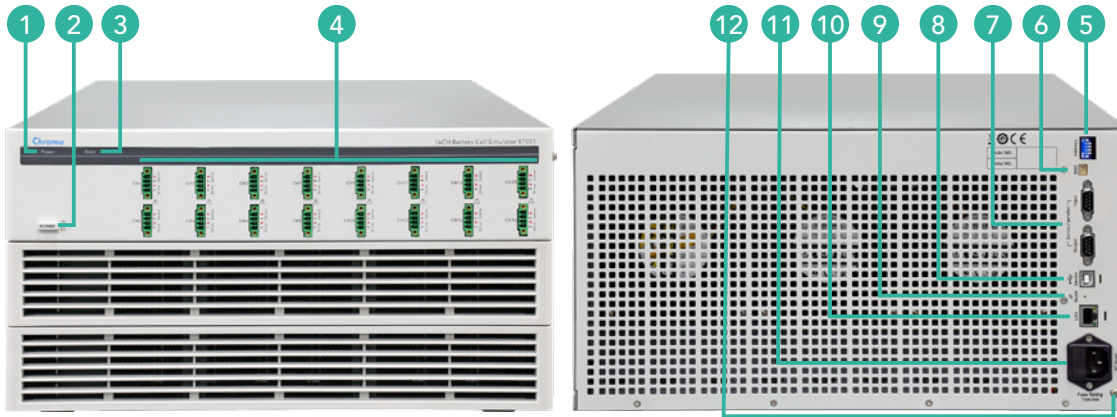

1. Power LED
2. States LED
3. Power Switch
4. Output Connector
5. ADDRESS
6. EMO
7. SERIES/PARALLEL
8. N/A
9. IP Reset
10. Ethernet
11. AC Input
12. GND Terminal

SPECIFICATIONS

Model	87001
Channels	16
Power Out	Max. 560W
Constant Voltage	
0~ 5V	Setting Range : 0~5000mV Accuracy : $\pm(0.02\%$ of F.S.) Setting Resolution : 0.5mV Reading Range : 0~5200mV Accuracy : $\pm(0.02\%$ of F.S.) Reading Resolution: 0.1mV
Constant Current	
0~ 500mA	Setting Range : 0.1~500mA Accuracy : $\pm(0.02\%$ of F.S.) Setting Resolution : 0.1mA Reading Range : 0~520mA Accuracy : $\pm(0.02\%$ of F.S.) Reading Resolution: 0.01mA
0~ 5A	Setting Range : 1~5mA Accuracy : $\pm(0.02\%$ of F.S.) Setting Resolution : 1mA Reading Range : 0~5.2A Accuracy : $\pm(0.02\%$ of F.S.) Reading Resolution: 0.1mA
Protection Function (w/ Software)	
Protection	OVP, UVP, OCP, OQP, OTP, ODVP, UDVP, ODCP, UDCP
Transient overvoltage Mains Supply	2500V
Isolation Voltage	1000V CH-TO-CH 2000V CH 2000V CH-TO -GND

Program Response Time			
Current Rise/Fall Times	100us (condition: 0A to 5A @200cm Wire)		
Programming Voltage Speed	Full load	Up	1m sec.
	No Load	Down	1m sec.
Load Regulation	Voltage	<0.01% + 2 mV	
	Current	<0.01% + 250 μ A	
Line Regulation	Voltage	<0.01% + 2 mV	
	Current	<0.01% + 250 μ A	
Ripple and Noise	Voltage	<0.35 mV rms	
	Voltage	<2 mV p-p	
	Current	<2 mA rms	
General Specifications			
Operable Environment	0°C ~40°C 0~90% RH (non condensing)		
Altitude	2000 m		
Input Voltage	1000V CH-TO-CH 2000V CH 2000V CH-TO-GND		
Input Current	Max. 10A		
Input Power	1.2kVA		
Safety & EMC	CE		
Communication Mode	Ethernet interface		
Dimension (HxWxD)	428 x 221.3 x 696.8mm/ 168.5 x 871.3 x 274.3 inch		
Weight	42 kg/92.6 lb		

* Specifications are subject to change without notice.

Get digital catalog by downloading Chroma ATE Solutions APP



iOS

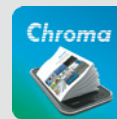

Android

Search Keyword

87001

ORDERING INFORMATION

87001 : 16CH Battery Cell Simulator

HEADQUARTERS
CHROMA ATE INC.
66 Huaya 1st Road,
Guishan, Taoyuan
33383, Taiwan
T +886-3-327-9999
F +886-3-327-8898
www.chromaate.com
info@chromaate.com

U.S.A.
CHROMA SYSTEMS
SOLUTIONS, INC.
19772 Pauling,
Foothill Ranch,
CA 92610
T +1-949-600-6400
F +1-949-600-6401
www.chromausa.com
sales@chromausa.com

EUROPE
CHROMA ATE
EUROPE B.V.
Morsestraat 32,
6716 AH Ede,
The Netherlands
T +31-318-648282
F +31-318-648288
www.chroma.eu.com
sales@chroma.eu.com

CHROMA ATE
GERMANY
Südtiroler Str. 9, 86165,
Augsburg, Germany
T +49-821-790967-0
F +49-821-790967-600
www.chroma.eu.com
support-germany@chroma.eu.com

JAPAN
CHROMA JAPAN
CORP.
888 Nippa-cho,
Kouhoku-ku,
Yokohama-shi,
Kanagawa, 223-0057
Japan
T +81-45-542-1118
F +81-45-542-1080
www.chroma.co.jp
info@chroma.co.jp

KOREA
CHROMA ATE
KOREA BRANCH
3F Richtogether
Center, 14,
Pangyojeok-ro 192,
Bundang-gu,
Seongnam-si,
Gyeonggi-do
13524, Korea
T +82-31-781-1025
F +82-31-8017-6614
www.chromaate.com
erica.shih@chromaate.co.kr

CHINA
CHROMA ELECTRONICS
(SHENZHEN) CO., LTD.
8F, No.4, Nanyou Tian
An Industrial Estate,
Shenzhen, China
PC : 518052
T +86-755-2664-4598
F +86-755-2641-9620
www.chroma.com.cn
info@chromaate.com

SOUTHEAST ASIA
QUANTEL PTE LTD.
(A company of Chroma Group)
46 Lorong 17 Geylang # 05-02
Enterprise Industrial Building,
Singapore 388568
T +65-6745-3200
F +65-6745-9764
www.quantel-global.com
sales@quantel-global.com