

Power Electronics Testing



Electric Vehicle Test Solutions

www.chromaate.com



Chroma

Turnkey Test & Automation Solution Provider



Chroma, founded in 1984, is one of the World's leading suppliers of Automatic Testing Equipment (ATE) and provides test and measurement instrumentation and systems for various technology related industries. We specialize in turn-key test and automated solutions, which work in conjunction with manufacturing execution systems (MES).

Chroma's strength lies in test and measurements for: power electronics, passive component, electrical safety, video & color, LCD/LCM, automotive electronics, and semiconductor industries. More importantly, Chroma supports the clean energy initiative by providing solutions to test photovoltaics, LEDs, Li-batteries, power battery packs, electric vehicles and any ongoing new eco-driving industry developments.

In addition to having a large diverse group of R&D engineers, Chroma puts a large investment in research and development each year to ensure its continued technological leadership. Core technologies in power electronics and optics have fueled Chroma's drive forward into various new markets and success in providing innovative new test solutions with precision, reliability, and uniqueness.

Chroma Group & Global Operation Sites

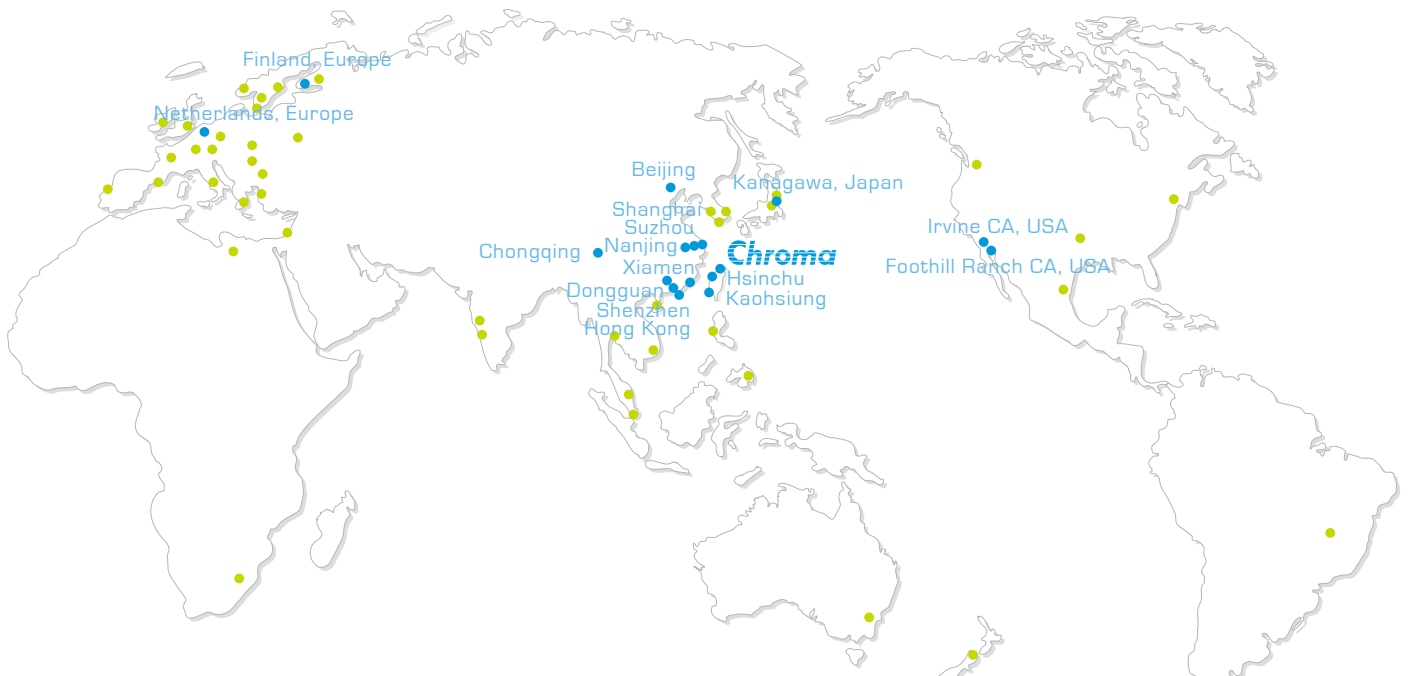

CHROMA GROUP			
CHROMA ATE INC.			
Newworld H.K.	Chroma/USA	MAS Automation/Taiwan	Chroma New Material
Chroma/Beijing	Chroma/Netherlands	MAS Automation/Nanjing	Testar Electronics
Chroma/Shanghai	Chroma/Finland	MAS Automation/Xiamen	ADIVIC Technology
Chroma/Suzhou	Chroma/Japan		ADLINK Technology
Chroma/Chongqing	Chroma Investment		DynaScan Technology
Chroma/Xiamen			EVT Technology
Chroma/Shenzhen			
Chroma/Dongguan			

Power Electronics Test Instruments

Over the years, Chroma ATE has gained extensive knowledge and know-how through participation in the electronics test industry by providing the right solution throughout different phases of product development and fabrication. These test solutions are not limited to power testing and are offered throughout the EV/PHEV industry.

Chroma ATE offers various AC/DC power source and electronic load products with a broad selection of power ratings, ranging from several hundred watts to a few hundred kilowatts, which can be used to test EV/PHEV related components and devices. Utilizing these in conjunction with our versatile automated test system, provides a full range of test solutions for EV/PHEV related applications such as battery storage systems, EVSE charger stations, DC/DC converter units and motor traction drivers.



Programmable AC Source 61500 Series Regenerative Grid Simulator 61800 Series

- 0.5kW-60kW/ 1 or 3-phase
- 150V/300V, 15Hz-1000Hz
- Parallelable for higher power up to 300kW
- Full 4 Quadrant/Regenerative Feature (61800 Series)



Transient Voltage Programming



Distorted Waveform Editor



Programmable DC Power Supply 62000H Series

- 5kW-15kW/ 0-1000V/ 0-375A
- High power density (15kW in 3U)
- Easy Master / Slave parallel & series operation up to 1.5MW

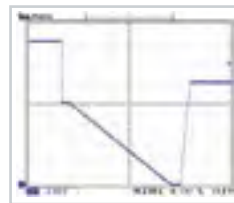

Battery Voltage Dropout

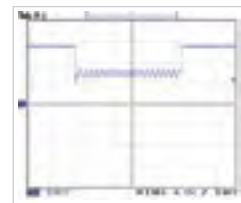

Engine Starting Profile of ISO 16750-2

Programmable DC Electronic Load 63200 Series

- 2.6kW-15.6kW/ 0-80V/ 0-1000V/ 0-1000A
- CC, CR, CV, CP load modes
- Master/Slave paralleling control mode up to 6 units
- Dynamic loading: Up to 20kHz
- Each Master/Slave parallel operation up to 93.6kW

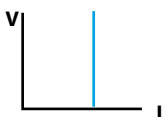

Constant Current

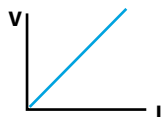

Constant Resistance

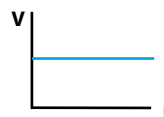

Constant Voltage

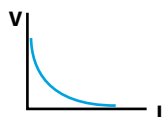

Constant Power

Programmable AC Electronic Load 63800 Series

- 1.8kW-4.5kW/ 50V-350V/ 45-440Hz
- V, I, PF, CF, P, Q, S, F, R, Ip+/- & THDv measurement
- Easy Master/Slave parallel & 3-phase operation up to 67.5kW

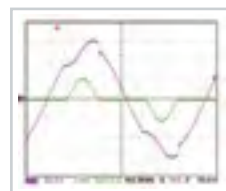

Rectified RLC Mode

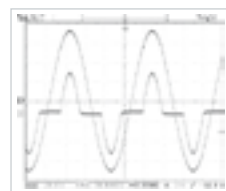

Programmable Crest Factor of Loading Current



High Performance Hardware Devices and Software Architecture

Automatic Test System - Chroma 8000

The power conversion section of the EV/HEV is composed of several power electronic units, which include the AC or DC EVSE (EV Supply Equipment), on-board charger, DC/DC converter, motor driver, etc. The Chroma ATS (Automatic Test System) addresses the specialized requirements involved in testing the power electronics during not only the development phase, but also the production phase. The benefits of our ATS are not limited to the reduction of manpower and prevention of human error; they also include advanced features such as automatic test data recording and creation of statistical analytical reports for later design review or product improvement. There are custom-built systems that are designed specifically for certain power electronic units; however, these systems are usually difficult to maintain and lack flexibility. These shortcomings will definitely impede the product development process as test methodologies evolve.

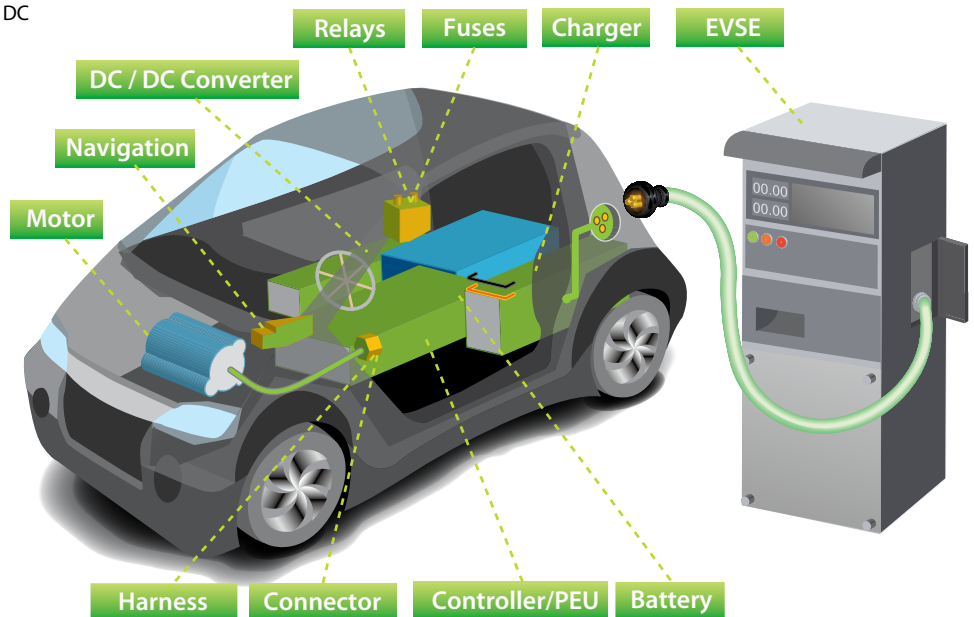

The Chroma 8000 ATS is a standard test platform that solves the conventional problem of self designed ATS's for power electronics testing. It is built on testing technology and experience in the power electronics industry, where Chroma has been a technological leader for nearly 30 years. Chroma has provided over 1,500 Chroma 8000 ATS's to customers worldwide that are being used in R&D, QA departments and production lines. Our test system is designed to have an open architecture, allowing the user to easily integrate various instruments. The Chroma 8000 ATS includes a wide range of hardware choices such as AC/DC power supplies, Electronic Loads, Power analyzers, Oscilloscopes, Digital multi-meters, as well as various digital/analog I/O cards. This flexibility combined with an open architecture gives the user an adaptable, powerful and cost effective test system for the EV/HEV power electronics. The Chroma 8000 test system includes a sophisticated test executive, which includes pre-written test items. Users may also create new test items by using the test item editor function. This provides the flexibility to expand your test library without limits. The Chroma 8000 ATS's ability to satisfying the test requirements for multiple power electronic units is key to keeping consistency and reducing costs during the transition between R&D and production.

The following pictures of the Chroma ATS show some applications for EV/HEV. The system will not only perform the tests and report it to an isolated PC, but it will also network to the shop-floor (MES) system for production line for data log-in, analysis and monitoring.



OBC/DC-DC Converter ATS

VMS ATS

EVSE (AC Level 1, AC Level 2) ATS

EV AC Charging Compatibility ATS

Software Platform of ATS Chroma 8000

PowerPro III

PowerPro III provides users with an open software architecture suited to a wide range of applications and devices. The test item editor is a powerful tool which is similar to C language, but much easier to use. It allows users to define test procedures, test condition variables, test result variables and temporary variables. The test program editor also provides a useful means to link several pre-defined test items for batch testing.

PowerPro III includes extended reporting capabilities, statistic and management functions, various test document generation and system administration. The unique report wizard and generator provide the total solution for any documentation requirement. It allows users to integrate different types of presentations, like tabular test data, DSO waveform and correlation charts in M/S WORD format. Users may also edit and store report formats for future use, thus saving time creating test reports. The Statistic function provides off-the-shelf statistical reporting tools. All the test conditions defined in the test program as well as the test readings can be stored and analyzed by the statistic report function. The report and raw data may be printed out or stored in a file.

Power Pro III runs under the Windows 2000/XP/7 operating environment, providing the test engineer a dedicated test system with easy access to Windows resources.

Customized Test Fixtures

The test fixture, a device that interfaces between the ATS and the UUT, is a necessary for EV/HEV power electronics unit testing. Due to the different form factors and various connector types, it is impossible to find an off the shelf test fixture that can fit all testing requirements. The Chroma 8000 ATS support team not only helps to plan and develop the ATS, but they also provide their expertise to tailor a test fixture to the customer's needs.

Electrical Safety Test

Electrical safety test is the most important for electric vehicles as persistent electrical quality is requisite for the drivers that have to drive the cars everyday. For the environment the electric vehicles are in use, the application of electrical safety covers the power system, the charging system, the power wiring, the charging line, the charging connector and the charging station, etc.

Standards

- ☑ Isolation resistance Test (ISO 6469-1, GB/T 18384-1)
- ☑ Withstand voltage test (ISO 6469-3, GB/T 18384-3)
- ☑ Continuity test for potential equalization (ISO 6469-3, GB/T 18384-3)
- ☑ Related standards : UL 2202, UL 2251, ECE R100, UL 2580, GB 18488

Electrical Safety Analyzer - Model 19032 Series

- ☑ Combines Hi-Pot, IR, GB, LC/ALC/DLC and Dynamic Function Test
- ☑ Equips the state-of-the-art Open Short Check (OSC) function that can make customers totally worry-free when testing the finished products

Electrical Safety Test Scanner - Model 19200

- ☑ Relay control and Module system
- ☑ Supporting WV/IR/GB Test, Function Test

Electrical Safety ATS - Model 8900

The safety testing requirements of EV related products, has more standards than the general electricity products in terms of testing items and multi-channel points. Therefore, Chroma 8900, Electricity Safety ATS, has provided an outstanding integrated testing solutions and multi-channel points to the customers.



Software Main Screen

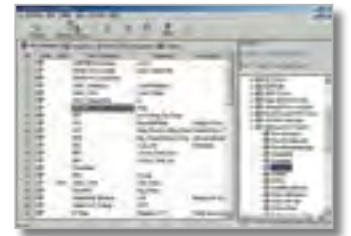

Test Item Editor

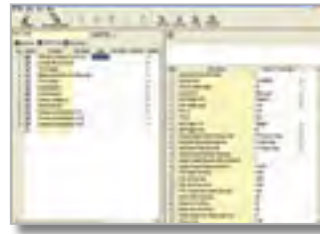

Test Program Editing



Running GO/NOGO

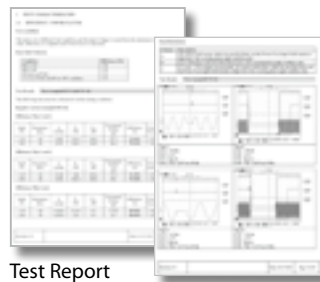

Test Report
M/S Word File



Statistic Report



Customized Test Fixtures



19032 Series



19200



8900



Customized ATS for EV/PHEV Maintenance Application

Charger station

The demand for charging stations is steadily growing as EV/PHEV's gain popularity. Unlike the conventional gas station, which mainly consists of mechanical parts, the EV/PHEV charging station has implemented sophisticated electronics for metering, controlling, and measuring the amount of energy required and transferred to the vehicle. In order to keep the charging station in optimum operating condition and maintain its accuracy, frequent service and calibration is required. Chroma ATE has the capability to provide a customized mobile service system, which is specifically designed to perform diagnosis, measurement and meter calibration for these charging stations.

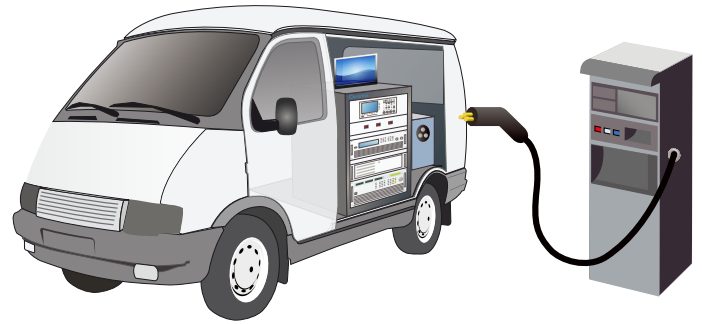

Auto Service

With the powertrain system switching from internal combustion engine (ICE) mechanical design to fully electric powertrain design, ICE oriented auto mechanics must quickly familiarize themselves with the electrified system. In order to provide optimum vehicle operating conditions, maintain serviceability and minimize the chance of a mechanics exposure to electric shock hazards, the Chroma 8000 provides unique, dynamic diagnostic capabilities. These include: vehicle battery unit testing, voltage/current parameter measurement reading, CAN bus interface, diagnostic reporting, etc. The test system provides diagnostic data through the internet directly to the vehicle manufacturer for data analysis.

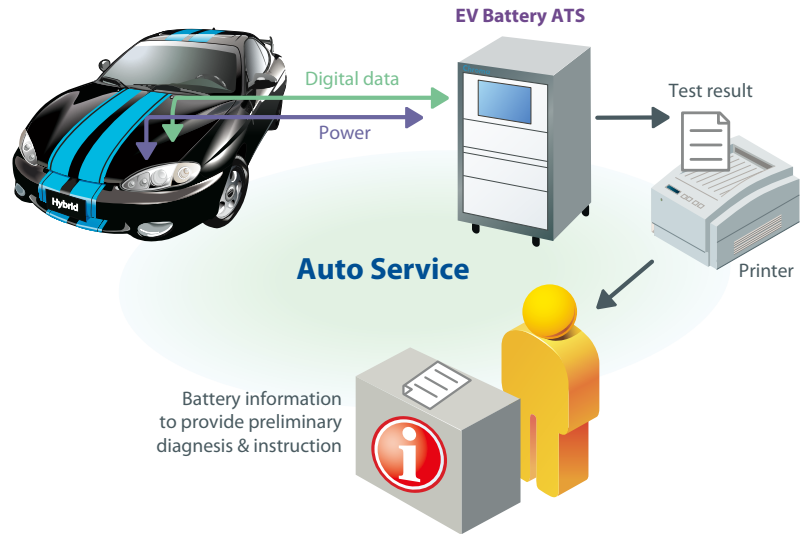

Battery Pack/Module Testing Regenerative Battery Pack Test System 17030/17020 Series

The 17030 system is a high precision integrated solution specifically designed for high power battery pack tests. Accurate sources and measurements ensure the test quality that is suitable for performing exact and reliable testing that is crucial for battery pack incoming or outgoing inspections, as well as capacity, performance, production and qualification testing.



Model 17030

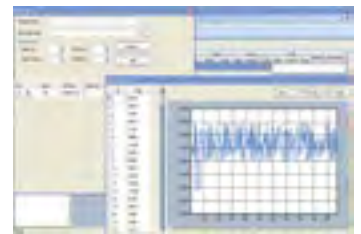

Driving cycle simulator

Key Features - Model 17030

- ☑ Charge / discharge mode : CC/CV/CP/Waveform Current
 - Voltage range : 10~1200V
 - Current range : 0~1000A
 - Power range : 90~350kW (Parallelable : Max. 4units)
- ☑ High precision measurement accuracy
 - Voltage : 0.05%+0.05% FS
 - Current : ±0.1%FS
- ☑ Driving cycle simulator
 - 720,000 points of driving profile memory, download from Excel file
 - Minimum Δt : 10ms
- ☑ Voltage / Current sampling rate : 50kHz for calculating dynamic charge / discharge capacity
- ☑ System integration : BMS interface, Chamber, Data logger
- ☑ Regenerative battery energy discharge

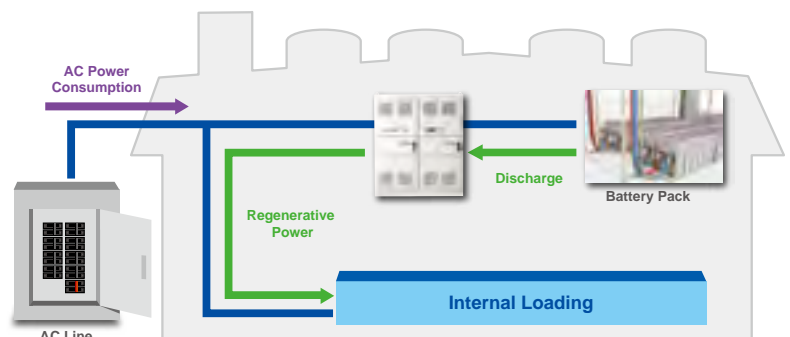

Regenerative function

Chroma's 17020 system is equipped with multiple independent channels to support dedicated charge/ discharge tests, on multiple battery modules / packs, each with discrete test characteristics. The channels can easily be paralleled to support higher current requirements. This feature provides the ultimate flexibility between high channel count (max 60 channels) and high current testing.

Key Features - Model 17020

- ☑ Charge / discharge mode : CC/CV/CP
 - Voltage Range : 20V / 60V / 100V
 - Current Range : 12A / 50A / 60A
 - Power Range : 600W / 1250W / 2500W for one channel (Max. parallelable channel : 60 channels)
- ☑ High precision measurement accuracy
 - Voltage : 0.02% rdg.+0.02% F.S. / 0.1% rdg.+0.05% F.S.
 - Current : 0.05% rdg.+0.05% rng / 0.1% rdg. + 0.05% rng.
- ☑ Driving cycle simulator
 - 720,000 points of driving profile memory, download from Excel file ;
 - Minimum Δt : 10ms
- ☑ Voltage / Current sampling rate : 50kHz for calculating dynamic charge / discharge capacity
- ☑ DCIR function (IEC 61960-2003)
- ☑ Regenerative battery energy discharge
 - Efficiency : About 85% at above 20% of rated power

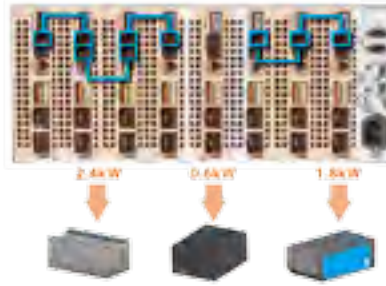

Channels parallelable for higher current



Model 17020 8 channels

Model 17020 16 channels



Flexible system configuration

Battery Cell Testing

Programmable Charge/Discharge Tester 17011

Chroma 17011 series is a precision test charge/discharge test system specifically designed for Lithium-ion secondary battery and EDLC. The features of this system are typically required to perform applications of cell cycle life test, QC, material research, and etc.

Key Features

- ☑ CC/CV/CP Charge & Discharge Modes
 - Voltage Range : 0~5V ; Current Range : 20A/30A/100A
- ☑ High accuracy Voltage & Current Measurement
 - Voltage : 0.02% rdg.+0.02% F.S
 - Current : 0.02% rdg+0.02% rng/ 0.03% rdg. + 0.03% rng.
- ☑ Battery DCIR Charge & Discharge Mode Functions
 - Build-in DCIR Charge & Discharge modes, produce DCIR value
- ☑ EDLC Charge & Discharge Modes
 - Follow IEC 62391 to test EDLC capacitance
- ☑ High Sampling Time up to 10ms
- ☑ Test channel parallel function for higher test current rating
 - Maximum parallelled test current : 600A

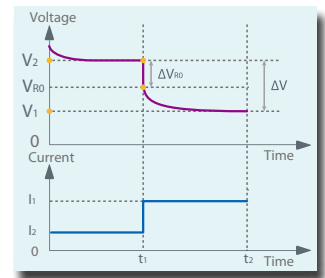
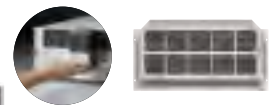

DCIR Test

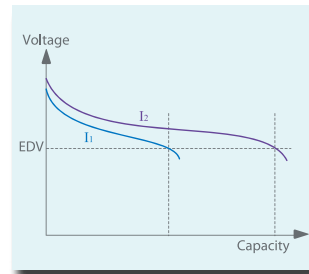

Capacity Testing

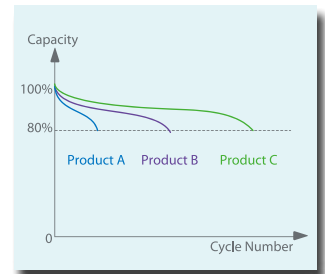

Cycle Life Testing

Software Platform Battery Pro

The Battery Pro Platform is specifically designed to meet the various requirements for testing secondary battery packs with high safety and stability. Charge and discharge protection aborts tests when abnormal conditions are detected. Data loss, storage and recovery are protected against power failure.

Software Integration - Model 17030/17020

- ☑ BMS communication interface : Collecting BMS data to control charge/discharge profile and protection setting
- ☑ Data logger : Collecting measured battery cell voltage and temperature to control test procedure and protection setting
- ☑ Thermal Chamber : Synchronizing temperature control with charge/discharge profile



Main Menu



Real-time Multi-channel Monitor



Diversified Reports

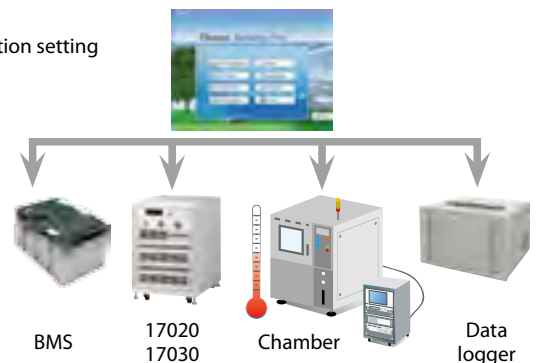

BMS

17020
17030

Chamber

Data
logger



HEADQUARTERS
CHROMA ATE INC.
T +886-3-327-9999
F +886-3-327-8898
info@chromaate.com
www.chromaate.com

CHINA
CHROMA ELECTRONICS (SHENZHEN) CO., LTD.
T +86-755-2664-4598
F +86-755-2641-9620

JAPAN
CHROMA JAPAN CORP.
T +81-45-542-1118
F +81-45-542-1080
www.chroma.co.jp

U.S.A.
CHROMA SYSTEMS SOLUTIONS, INC.
T +1-949-600-6400
F +1-949-600-6401
sales@chromausa.com
www.chromausa.com

CHROMA ATE INC. (U.S.A.)
T +1-949-421-0355
F +1-949-421-0353
Toll Free +1-800-478-2026
info@chromaus.com
www.chromaus.com

EUROPE
CHROMA ATE EUROPE B.V.
T +31-318-648282
F +31-318-648288
sales@chromaeu.com
www.chromaeu.com