

## DUST TEST CHAMBERS

**For checking the protection against solid foreign objects to verify the degrees of protection IP5X "Dust-protected" and IP6X "Dust-tight"**

In accordance with IEC 60529/1989-11 § 13.1 Tab. VII Fig. 2, EN 60529/1991 § 13.1 Tab. 7 Fig. 2, - VDE 0470 Part 1/1992-11 § 13.1 Tab. 7 Fig. 2 1

### Sense and Purpose

Enclosures with the degree of protection IP5X "Dust-protected" do not have to prevent ingress of dust totally. However, dust should not penetrate in an amount sufficient to interfere with the satisfactory operation of the equipment enclosed or to impair safety. In the case of enclosures with degree of protection IP6X "Dust-Tight", it is necessary to prove that no dust can penetrate into the inside of the enclosure.

### Test Equipment

The tests are carried out by means of a dust chamber with a sealed test cabinet, in which talcum powder is kept in suspension by means of an air stream. The talcum powder must be prepared in such a manner that it will pass through a sieve with a mesh size of 0.075mm.

The quantity of talcum given in the regulation is 2 kg per cubic meter of test cabinet volume.

### Test Procedure

The enclosure under test, in the following called specimen, is suspended in the test cabinet and - if prescribed - connected to a vacuum pump. This produces inside the specimen a depression of maximum 2 kPa = 20 mbar (= approx. 200 mm water column) below atmospheric pressure.

The test is completed after 2 hours, if within 2 hours 80 to 120 times the air volume of the specimen has been drawn through.

### Special Conditions

If it is not possible using the maximum depression mentioned above, to draw at least 80 times the air volume through the specimen within 2 hours, the test should be continued until this value has been achieved. According to the prescriptions, the specimen should not be tested for more than 8 hours.

The allowable quantity of talcum powder entering into the specimen should be agreed upon between the manufacturer and the user of the equipment.

### Standard Outfit:

- 1 test cabinet (1) with inner dimensions: width = 800 mm, height = 900 mm, depth depending on size, with solid door threshold suitable for supporting heavy specimens
- 1 to 3 funnel shaped bottoms (2), coarse meshed protective grids (3) to protect the dust circulation pumps from large parts, with deflection sheets (5) above the intake openings to protect the dust circulation pumps from small solids,
- 1 front door (6), with latches, with adjustable rubber seal, with hinges at the right and handle (7) at the left, surface of the window pane behind the door threshold, thereby scarcely any trickling of dust when the door is opened, window (8) with hand-operated window wiper



- 2 square slide rails (9) with 1 or 2 slides (10) beneath the ceiling, to suspend the specimen (11),
- 1 to 3 dust circulation pumps (12) with transfer pipes (13) and dust distribution out- lets (14),
- 1 pressure equalizing air filter (15) with exchangeable cartridge,
- 1 to 3 electric vibrators (16) at the funnels, to remove dust deposition from the walls,
- 1 to 3 electric heating elements (17) inside of the test cabinet to keep the talcum powder dry to avoid agglomeration,
- 1 vacuum pump (18), to cause a depression inside of the specimen, adjustable from 0 to -30 mbar,
- 1 depression indicator (19), scale to -40 mbar, (manometer)
- 1 dust filter (20) with removable insert, to collect the dust, which has been exhausted out of the specimen,
- 1 air volume meter (21) (flow meter),
- 1 vacuum connecting fitting with shut-off valve (22) in the test cabinet behind the door, with hose (23), 2 m long, to connect the specimen,
- 1 socket-outlet (24) inside of the test cabinet for energizing the specimen, two-pole with side earthing contacts, connectable to a separate voltage source.

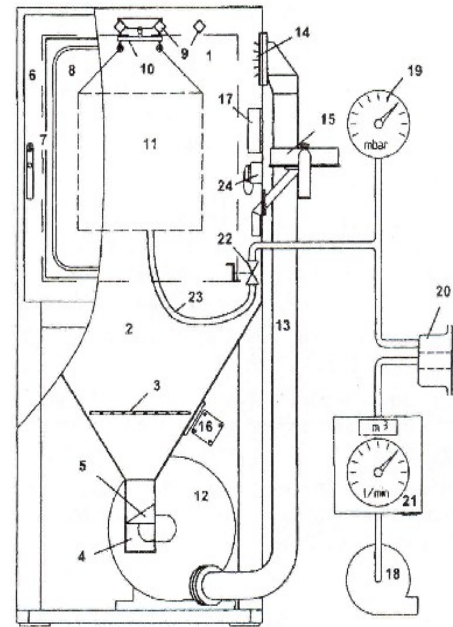

**In the control cabinet:** main switch, key switch, switches for the functions each, rotary knob to adjust infinitely the speed of the vacuum pump and therewith the depression, timer to control the vibration, pause length adjustable by means of a rotary knob in the front panel, running time adjustable inside of the control cabinet.

### Selling sizes and outfit variants:

Test Cabinet Internal Depth:	Dust Chamber external Depth *):	Dust Pumps, Vibrators:	Slides for Specimens:	Test Cabinet Walls:	Model No.:
800mm	1000mm	1	1	Painted Steel	<b>DTC-100</b>
1600mm	1800mm	2	2	Painted Steel	<b>DTC-200</b>
2400mm	2600mm	3	2	Painted Steel	<b>DTC-300</b>

External width 1320 mm \*), external height 1910 mm \*)

**Design:** manufactured from rectangular steel tubes and sheet steel, with 4 lockable dolly's (wheels), control cabinet with control and monitoring elements located on the right-hand side, **voltages and/or frequencies according to customer**

### Additional options:

**Rear door,** designed and equipped exactly like the front door, however mounted axially symmetrical to the front door in the rear wall (external depth of the dust test chamber in this case approximately 150 mm larger),

Model No.: **DTC-610**

**Unit timer** for switching the entire dust test chamber on and off automatically, 24 hours in steps of 15 minutes, with on-off switch, Model No.: **DTC-650**

**Program Timer** for switching the socket-outlet in the test cabinet on and off automatically, up to 5 switching-on and -off times in steps of 15 minutes with minimum difference of 30 minutes can be predetermined at will, with on-off switch, Model No.: **DTC-660**

**Interval timer** for switching the socket-outlet in the test cabinet on and off automatically continued, switching-on and pause periods can be predetermined separately, 0 to 30 minutes in each case, with on-off switch, Model No.: **DTC-670**

**Special outfit:**

**Three-phase socket-outlet** GEE 17, 16 A 3 P + N + PE, dust-tight, in the test cabinet for energizing the specimens, with dust-tight plug, instead of the 2 pole set, Model No.: **DTC-710**

**Other** socket-outlets: on request

**Accessories:**

**Talcum powder**, additional, for refill, 1 bucket with 10 kg, Model No.: **DTC-820**

**Testing sieve**, to check the talcum powder, nominal width of mesh 0.075 mm, Model No.: **DTC-830**

Sieve shaker also recommended – ask your rep for details

**Other sizes and special types,**

e. g. as described above, however for operation with coarse-grained dust, or according to other standards, as **DIN 40050 Part 9 § 7.3.1 Fig. 1, MIL**, or with dust injector according to **SAE J 726**: on request

**Peculiarities of Dust Test Chambers**

The door and the doorframe represent a strong tubular weldment...therefore; the door can be opened and closed in seconds with one grasp. The pane is made of safety glass. The door is shut off absolutely tight. The seal is easily and simply retensioned. Great care was taken to ensure that dust dispersion on opening the door would be minimized. By tapping the pane before opening, the dust falls into the funnel, as there are no internal projections under the pane.

2 slide rails are located below the ceiling for suspension of the specimens. The arrangement of these - with edge on top - has been chosen, to minimize dust settling on them.

Despite operation of the dust circulation pump, the heating of the air and operation of the vacuum unit, there should be no pressure rise or pressure drop in the test cabinet, referred to the ambient air pressure. For this reason, a pressure equalization system with amply dimensioned filter cartridge is part of the equipment.

A socket-outlet for 16A with dust-tight cover and with suitable plug, also dust-tight, is installed in the test cabinet. In the case of other socket-outlet types, ED&D should be consulted.

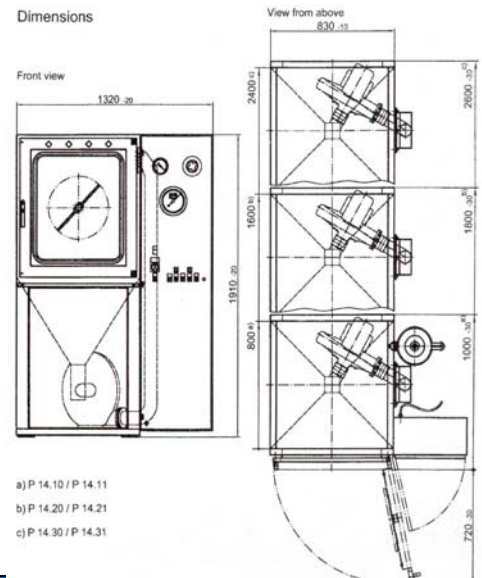

**Weights****DTC-100**

Net approximately 320kg (706lbs)  
 gross approximately 430kg (948lbs)

**DTC-200**

net approximately 550kg (1213lbs)  
 gross approximately 710kg (1565lbs)

**DTC-300**

net approximately 780kg (1720lbs)  
 gross approximately 990kg (2183lbs)

Units are packed and shipped in robust wooden crates - - all packing, packaging and handling costs are included in the price.

**Includes:**

- Wooden crating
- One year warranty
- Detailed User's Manual
- Free Expert-Level Technical Support
- Package of Talcum Powder
- **ISO 17025 Accredited Certificate of Calibration - - *in Scope!***

**ISO/IEC 17025 ACCREDITED in Scope for Dust Chambers**

ACLASS is an ILAC Member, equivalent to A2LA



**Inc. 500 | 5000**  
 ED&D is an Inc. 5000 Company

© ED&D, Inc. 2011 All rights reserved.