

**TEST PROBE KIT**

Model TPK-01 : For 60950 based STANDARDS







**Test Probe Kits:**



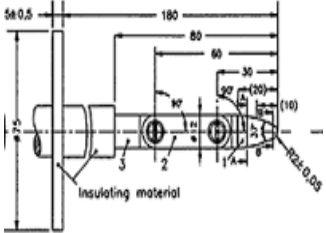

Several Different accessibility probe kits are available for specific standards. Kits can be created for other standards on request. Probe Kits offer substantial cost savings not to mention added convenience.

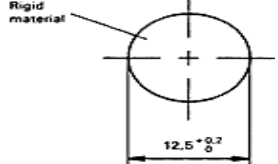
The TPK-01 contains the devices listed in the core of 60950 based requirements. It includes the following:

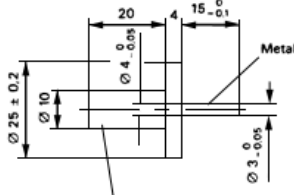
- IEC Jointed Finger Probe (w/ banana jack in handle) (TFP-01)
- 50mm Impact Test Ball (ITB-01)
- Test Pin Probe: short (TPP-01)
- Rigid Finger Probe (UFP-02)
- Ball Pressure Tester (BPT-01)
- Telecom Test Probe (TTP-01)

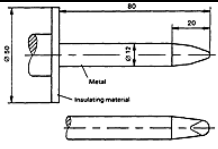
**Also includes:** custom-cut foam padded carrying case and ISO 17025 **accredited** Certificate of Calibration - - with *specific Scope* for "Accessibility Probes"!

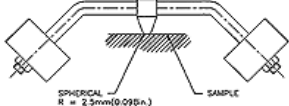
<p><b>TFP-01</b></p> 		<p>This is the "International" test finger required by most IEC, EN and CSA Standards, in addition to many UL Standards. Built in strict accordance to the newest requirements - with integral palm simulator. This is the ONLY Finger Probe available with an integral jack in the handle for continuity testing - as mandated by the IEC CB Scheme. Finger made of chrome plated steel. All parts precision machined.</p>
<p><b>ITB-01</b></p> 		<p>Complies with all IEC, EN, UL, CSA and International Standards which require a 50mm diameter, 500g impact ball. This ball is hardened steel with a chrome finish and is provided with a removable eyelet to allow for drop or pendulum use.</p>
<p><b>TPP-01</b></p> 		<p>Used to test accessibility through enclosure openings per IEC, EN, UL and CSA Standards. Body is Delrin, tip is stainless steel.</p>

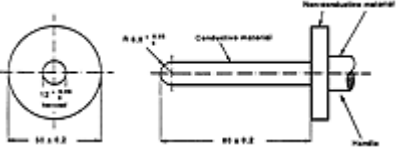
<p><b>UFP-02</b></p> 		<p>Used for force applications on openings (i.e. vents) as required by IEC, EN, UL and CSA Standards. Handle made of Delrin, rigid finger made of chrome plated steel.</p>
<p><b>BPT-01</b></p> 		<p>For testing plastics to which hazardous voltage parts are mounted (i.e. terminal blacks, transformer bobbins, etc...) in accordance with most IEC, EN Standards and internationally harmonized UL and CSA Standards (950, 1010, 601, 335, etc.). The unit exerts 20N force on sample. Entirely stainless steel. NOTE - this test is required to be conducted in an oven at elevated ambient.</p>
<p><b>TTP-01</b></p> 		<p>Required by IEC, EN, and some UL and CSA standards to test accessibility to TNV circuits (telecom). The handle and stop face are Delrin, the tip is stainless steel.</p>

NOTE: ED&D is the world's first and **only** ISO 17025 accredited firm to obtain specific Scope of Accreditation for the category "Accessibility Probes".

ED&D is accredited by the ANSI-ASQ National Accreditation Board under their brand "ACCLASS"



**Inc. 500 | 5000**

ED&D is recognized as the world's most highly awarded product safety test equipment manufacturer. ED&D is a multi-winner of the Fast 50 award as well as an Inc. 5000 award winning company!



© ED&D, Inc. 2004 All rights reserved.

**Educated Design & Development, Inc. ("ED&D")**

901 Sheldon Drive • Cary, NC • 27513 USA •

Phone: 800-806-6236 • International: 001-919-469-9434 • Fax: (919) 469-5743 •

email: [info@productsafet.com](mailto:info@productsafet.com) • Home page: [www.ProductSafeT.com](http://www.ProductSafeT.com).